



The Leveraged Freedom Chair (LFC) is the **mountain bike of wheelchairs**. It enables people with disabilities in developing countries to move beyond the pavement, providing them with the mobility they need to lead independent lives.

Great on and off road

Regular wheelchairs are designed for hospitals, not the rough terrain of developing countries. LFC riders push levers instead of the wheels, giving them the torque they need to move beyond the pavement.

Riders "shift gears" by sliding their hands up and down the levers. Grabbing low on the levers is a "high gear," while grabbing high on the levers is a "low gear." The levers can be removed and stored on the chair enabling the LFC to be used like a regular wheelchair indoors and in tight spaces.

Compared to hospital wheelchairs in rural village settings, it is:

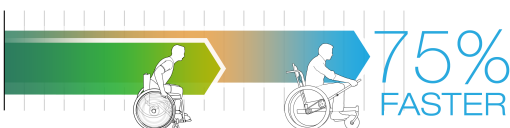

Designed and built to last

Wheelchair riders in developing countries already face a lot of obstacles, repairing their wheelchair should not be one of them. We designed the LFC out of available materials so it can be fixed anywhere.

“After I came back from the hospital, I gained confidence... I rested for a day at home and the next day went to my shop. **Now everything is back to normal.**”

Ashok, LFC rider
Jaipur, India



Website	www.goGRIT.org
Email	sales@goGRIT.org
Phone	+1 (617) 383-4748

Leveraged Freedom Chair

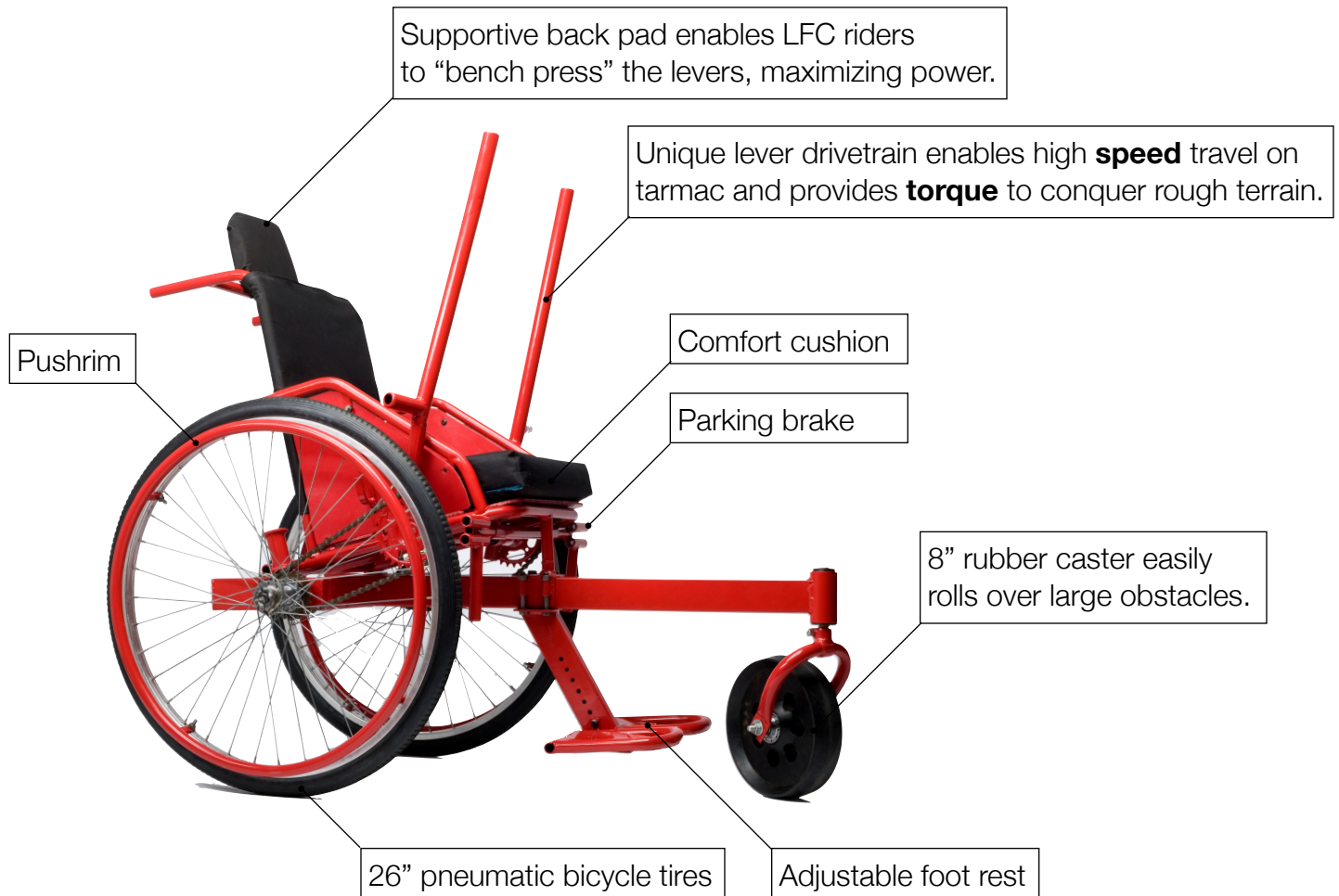

Features	
Intended User	adults without postural support needs
Drivetrain	storable lever drivetrain and pushrims
Gear Ratio	variable mechanical advantage from 1:1 to 3:1
Frame	rigid mild-steel frame with three wheels
Axles	adjustable rear axle position
Rear Wheels	26 in. (66 cm) pneumatic bicycle tires
Front Wheel	8 in. (20.5 cm) solid rubber front castor
Footrest	adjustable footrest with straps
Armrests	fixed armrest with mudguard
Support	comfort cushion, seatbelt, chest and foot straps
Bearings	bicycle ball bearings on all bearing surfaces
Repairability	repairable in a local bicycle shop

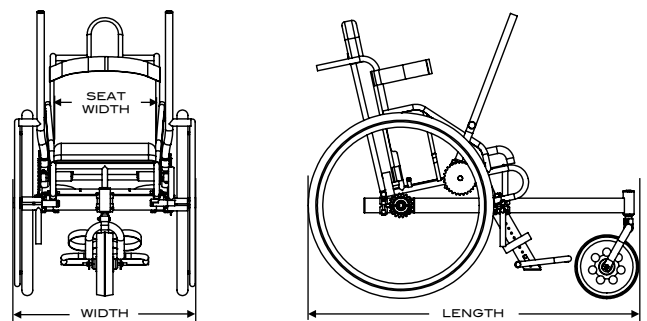

Measurements			
Seat Depth	14 in. (35.5 cm)		
Length	44 in. (112 cm)		
Sizes	Small	Standard	Large
Width	24 in. (61 cm)	26 in. (66 cm)	29 in. (74 cm)
Seat Width	13 in. (33 cm)	15 in. (38 cm)	18 in. (46 cm)
Weight	49 lbs. (22 kg)	51 lbs. (23 kg)	53 lbs. (24 kg)