

---

# ADJUSTMENT GUIDE

## UCP Expression Chair



# TABLE OF CONTENTS



<b>Tools needed</b>	<b>3</b>
<b>Adjustment :</b>	
<b>1. Footrest Height</b>	<b>4</b>
<b>2. Seat Depth</b>	<b>5</b>
<b>3. Back Tilt Angle</b>	<b>6</b>
<b>4. Back Height</b>	<b>7</b>
<b>5. Seat height</b>	<b>8</b>
<b>6. Caster</b>	<b>10</b>
<b>7. Center of Gravity</b>	<b>12</b>
<b>8. Brake</b>	<b>13</b>
<b>9. Tension back</b>	<b>14</b>
<b>10. Anti-Tip</b>	<b>15</b>
<b>11. Arm Rest</b>	<b>16</b>

# Tools needed

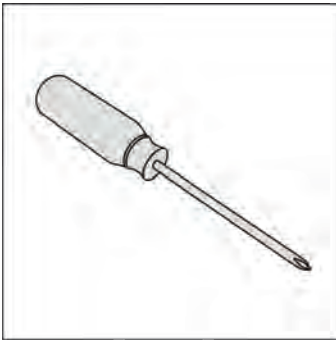

**Phillips Screw Driver**

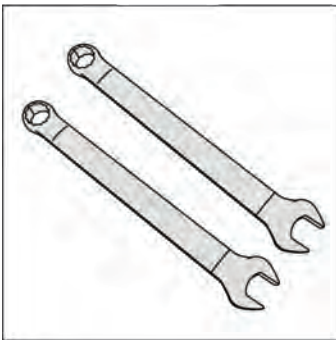

**2 Wrenches no. 13**

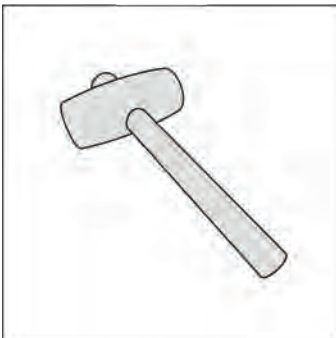

**Rubber Hammer**

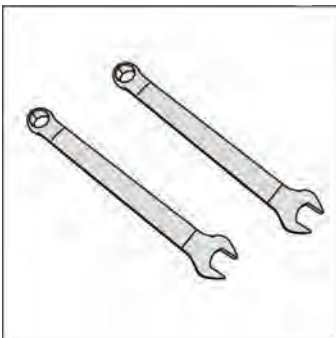

**2 Wrenches no. 10**

# 1. Footrest Height Adjustment

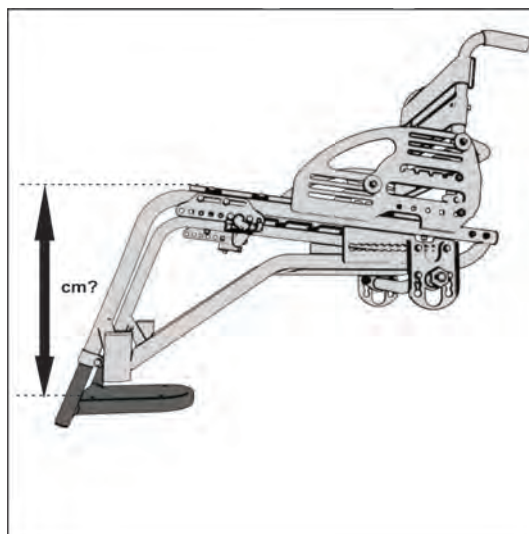
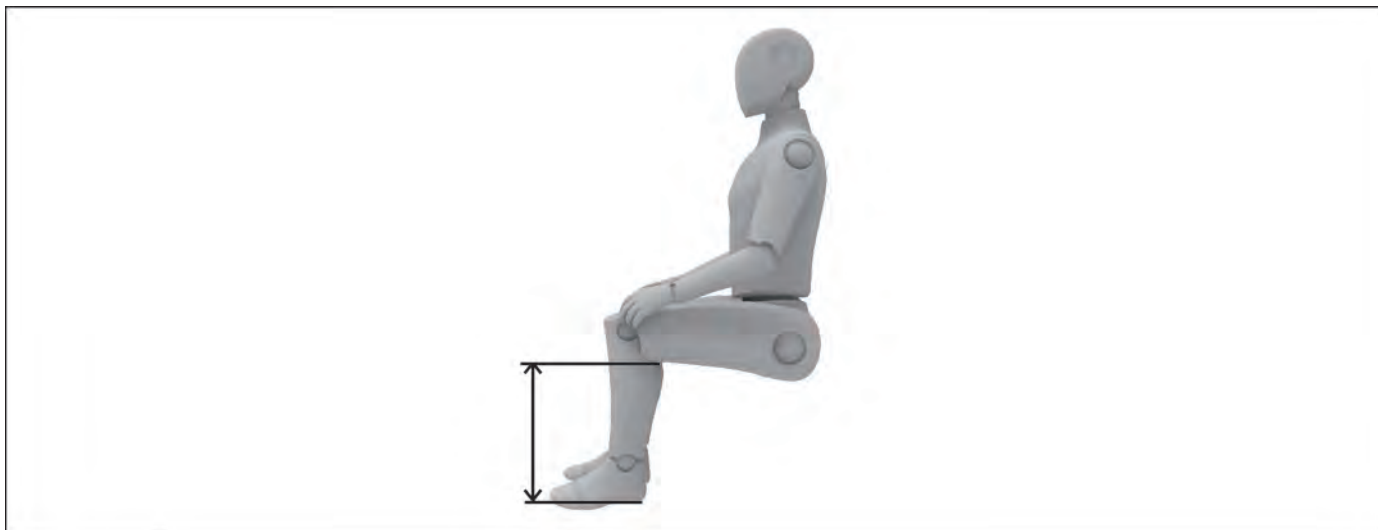

## STEP 1

Loosen the nut (left and right).

Adjust according to user's needs.

Note marks on tube.

# 2. Seat Depth Adjustment

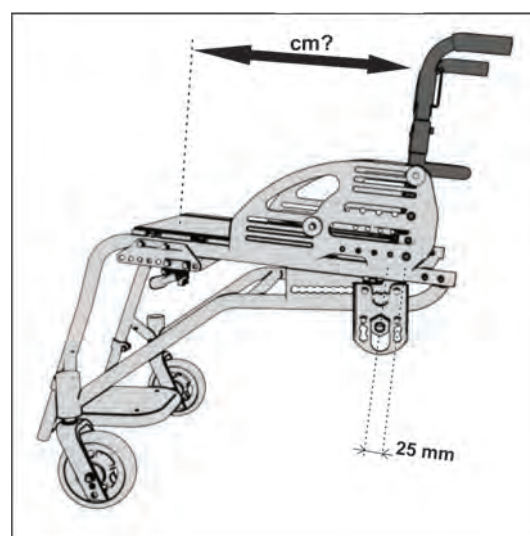
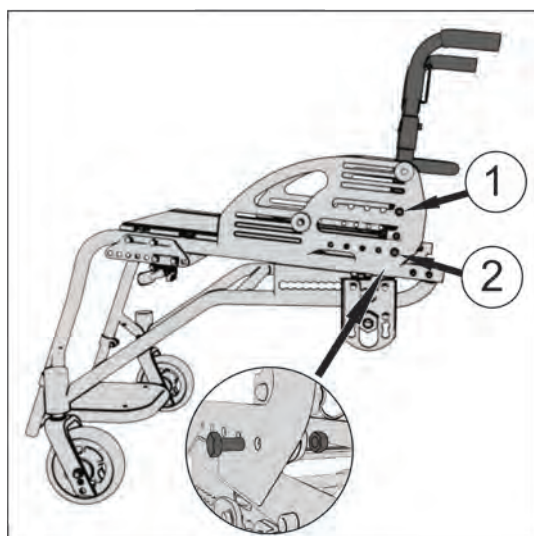
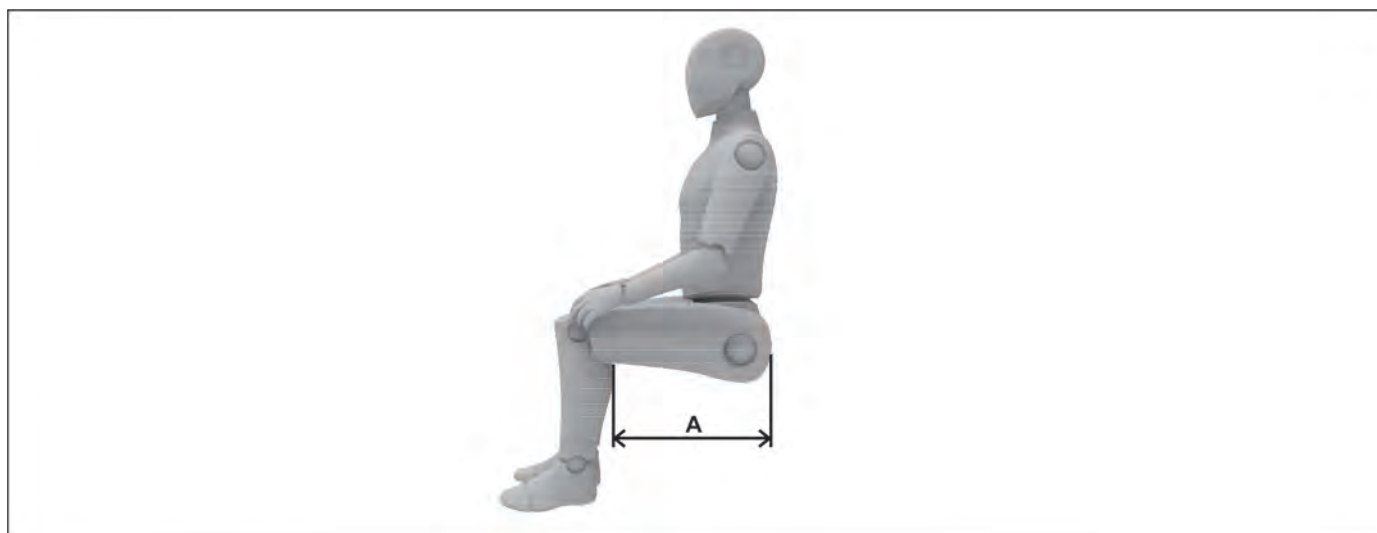

## STEP 1

Loosen bolt #1 and remove bolt #2.  
Lift and slide the back rest.

# 3. Back Tilt Angle Adjustment

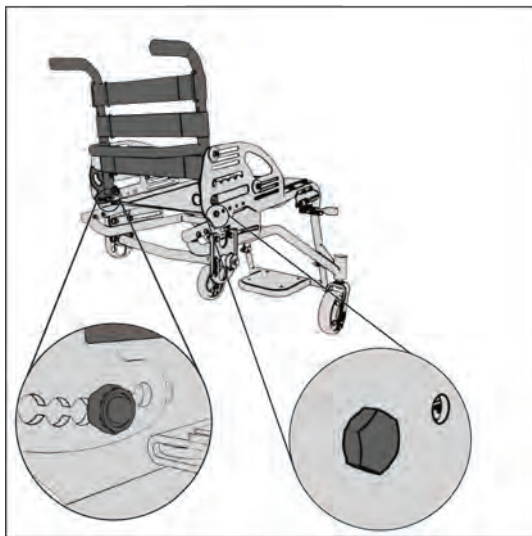
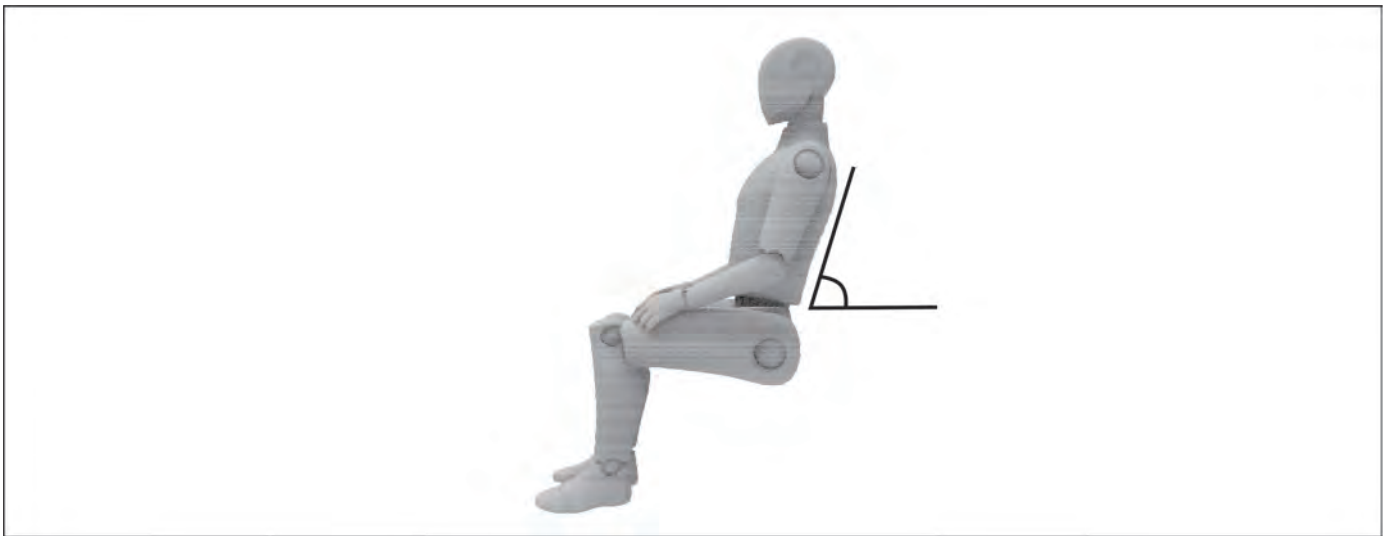

## STEP 1

Loosen & remove bolt and nut.

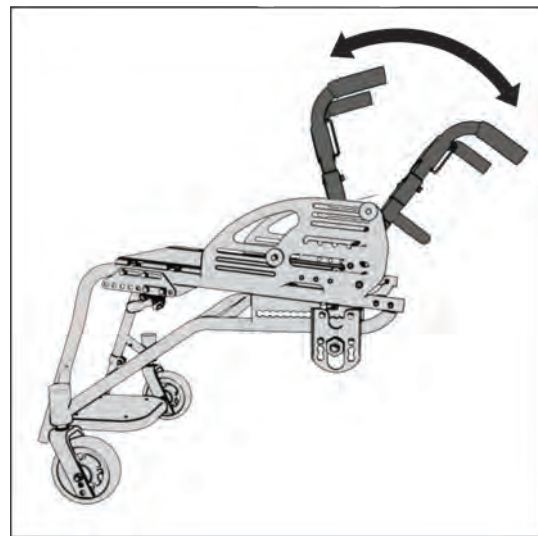

## STEP 2

Adjust backrest angle to fit the user's need. Re-install bolts and tighten all four nuts.

# 4. Back Height Adjustment

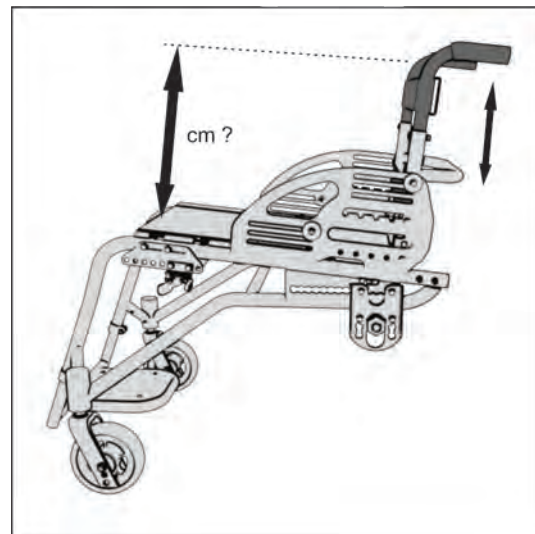
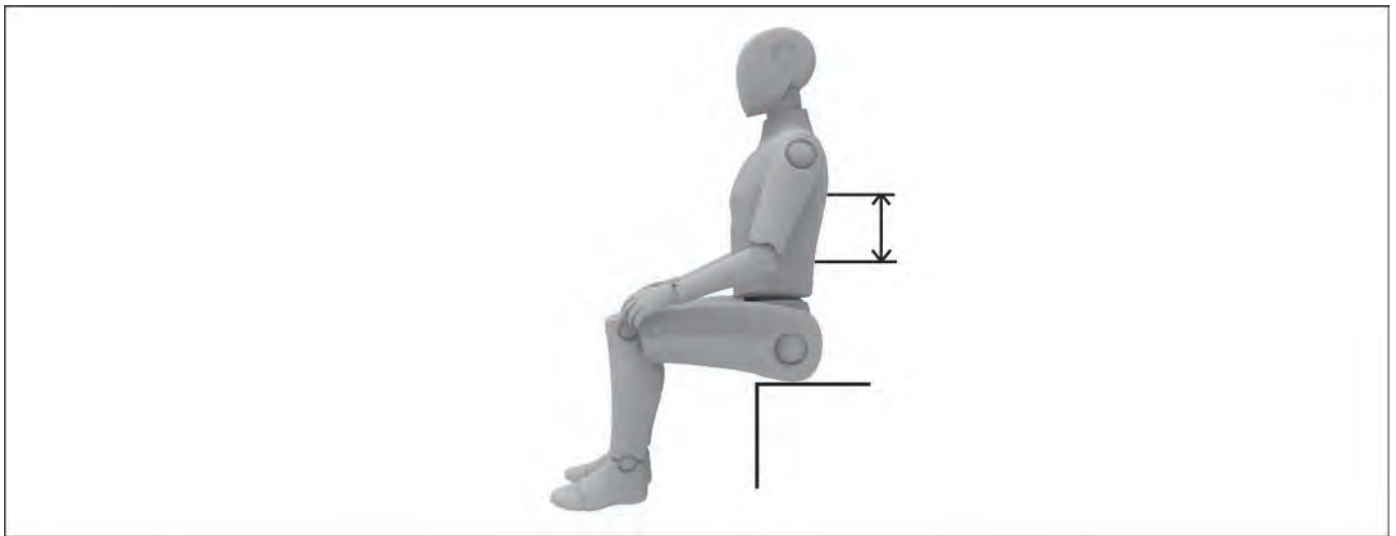

## STEP 1

To change back height, first remove tension adjustable back strap. Then remove the bolts.



# 5. Seat Height Adjustment

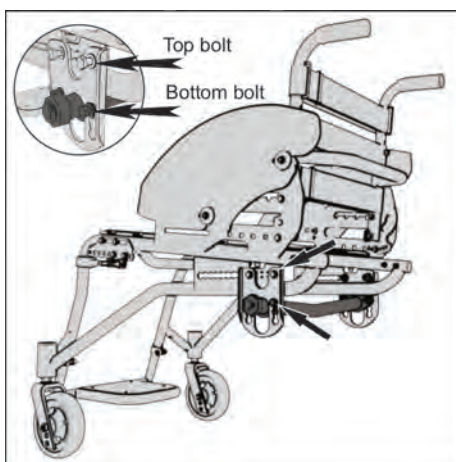
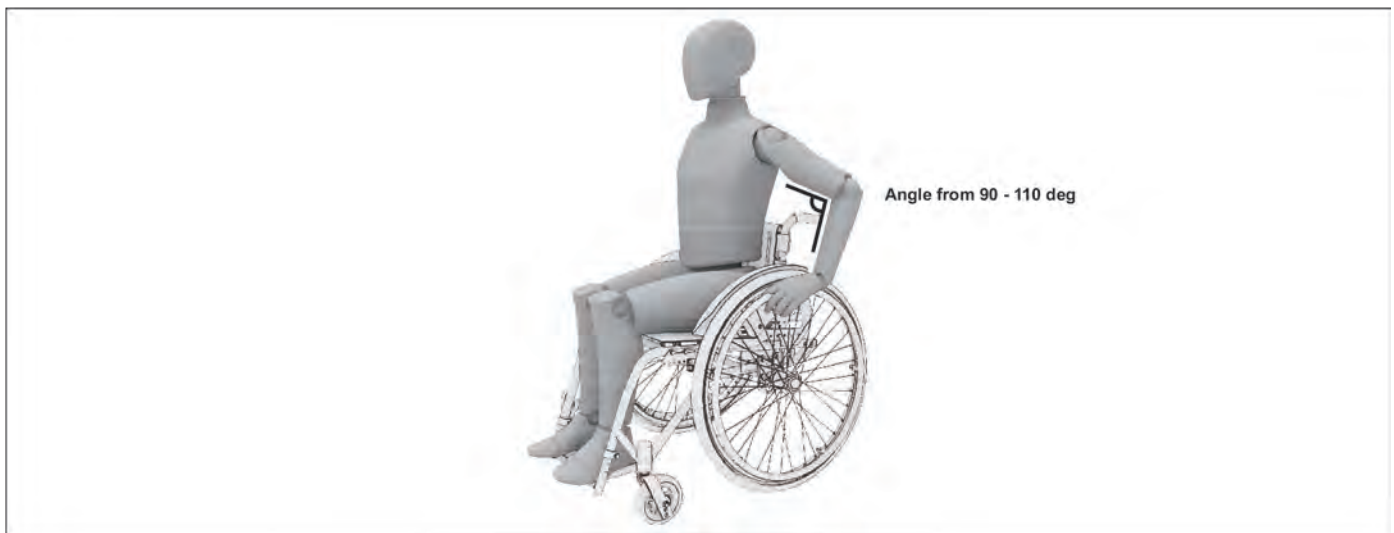

## STEP 1

Seat height adjustment helps put the user's arm in the strongest pushing position, with elbow at 90 when hand is at top of hand rim.

To start, loosen all four bolts on axle bracket.

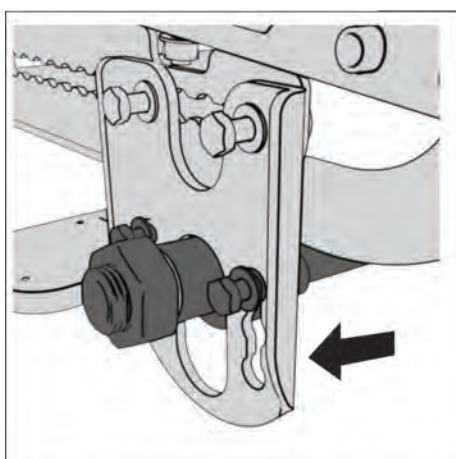

## STEP 2

Tap the bracket with a rubber hammer to move the bracket.

Note : When in correct position, tighten all four bolts.

Be careful to position nut holder tight inside the axle bracket.



# 5. Seat Height Adjustment

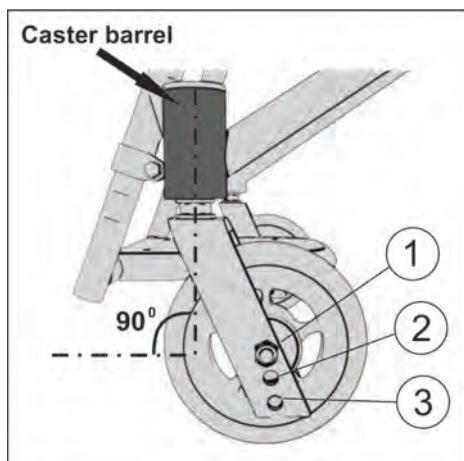

## STEP 3

The caster barrel must be at 90 degrees or the chair will be difficult to push and turn. Move the caster axle to the same position 1, 2, or 3. To start, use a 13mm wrench to remove the axle.

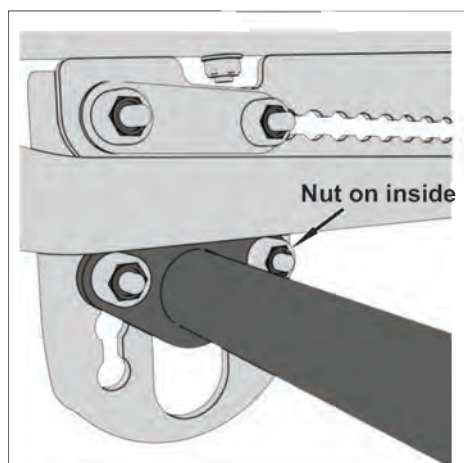
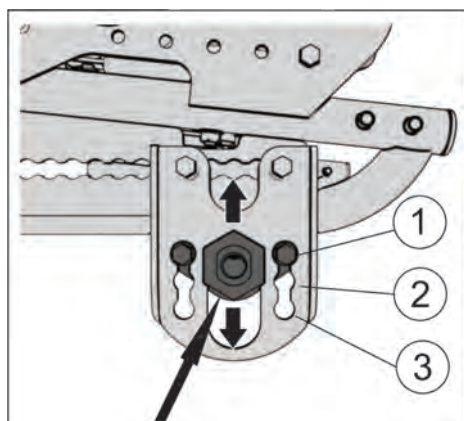

# 7. Center of Gravity Adjustment

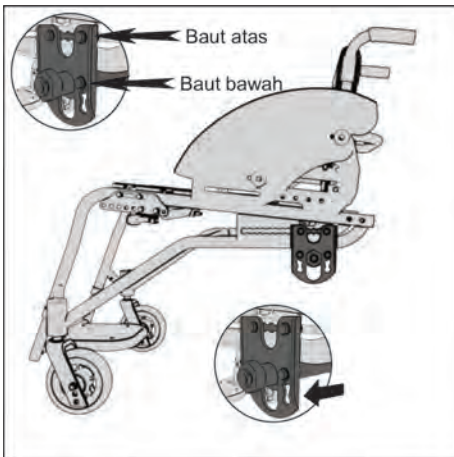

## STEP 1

Remove rear wheels, loosen top bolts & bottom bolts.

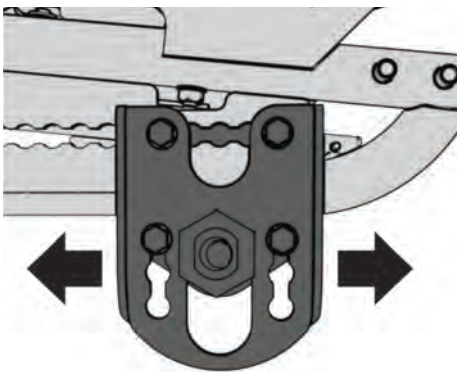

## STEP 2

Move as needed.

Carefully tighten bolts. Nut holders must be completely inserted.

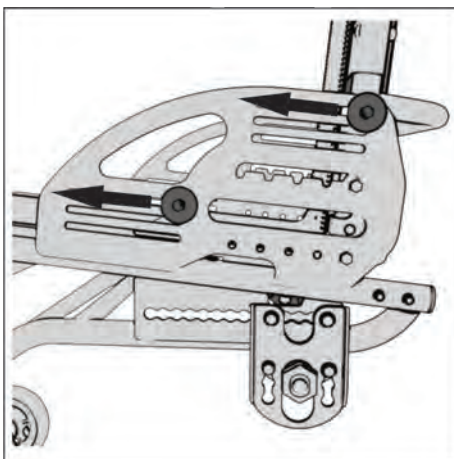

## STEP 3

Loosen nuts of fender holder. Adjust to the rear wheel position.

# 8. Wheel Lock Adjustment

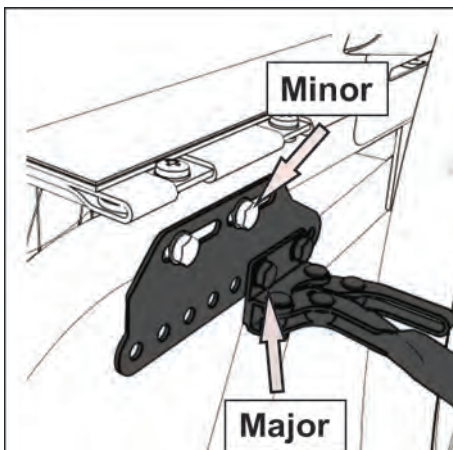

## STEP 1

Wheel locks should fully stop the wheel. There are two sets of adjustment bolts - major and minor. Make the major adjustment first.

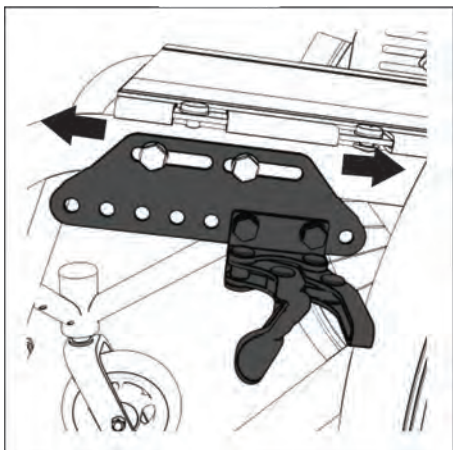

## STEP 2

Set minor adjustment so that wheel is fully stopped when wheel lock is engaged.

# 9. Tension Back Adjustment

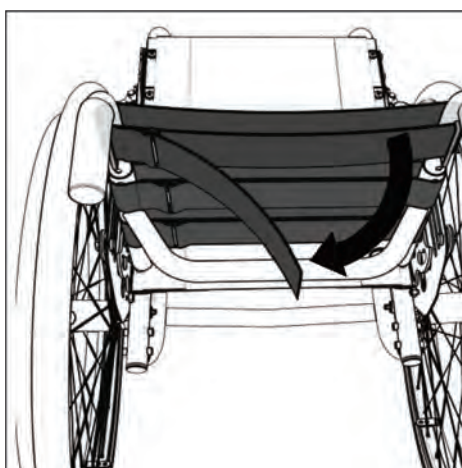

## STEP 1

Take off back cover & open velcro strap to start adjustment.

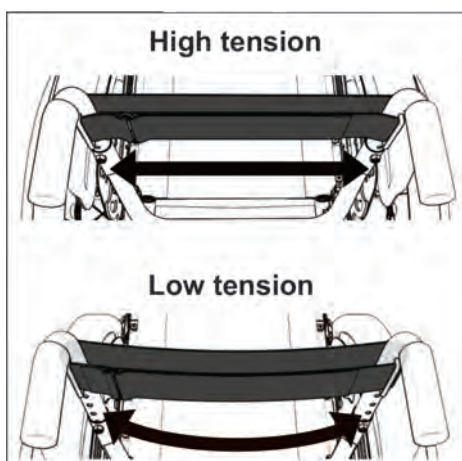

## STEP 2

Adjust the tension of the straps to match the curve of the user's back.

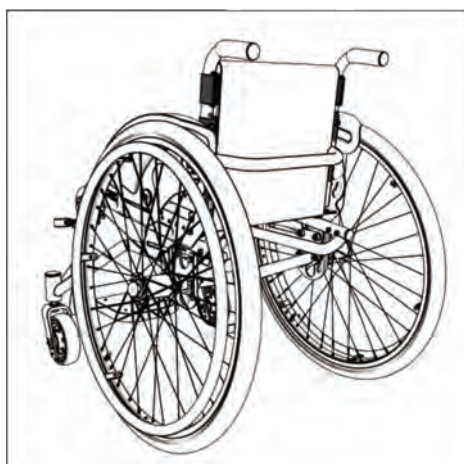

## STEP 3

Replace the back cover.

# 10. Anti-Tip Adjustment

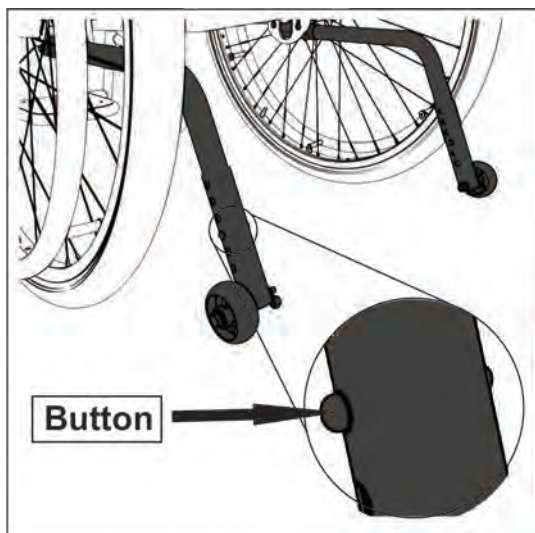

## STEP 1

Push the button on the tube of Anti tip.



# 9. Arm Rest Adjustment

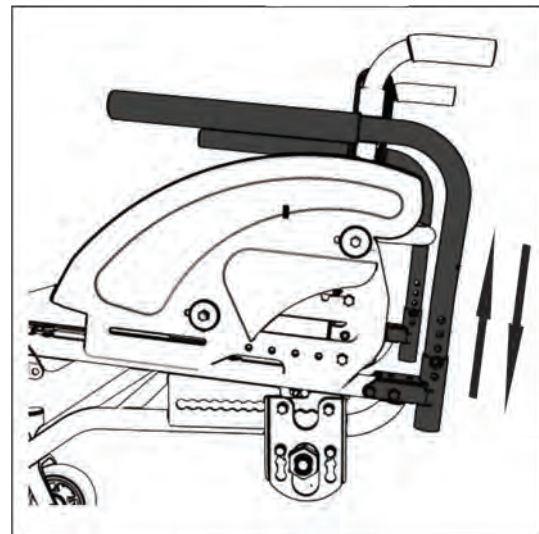
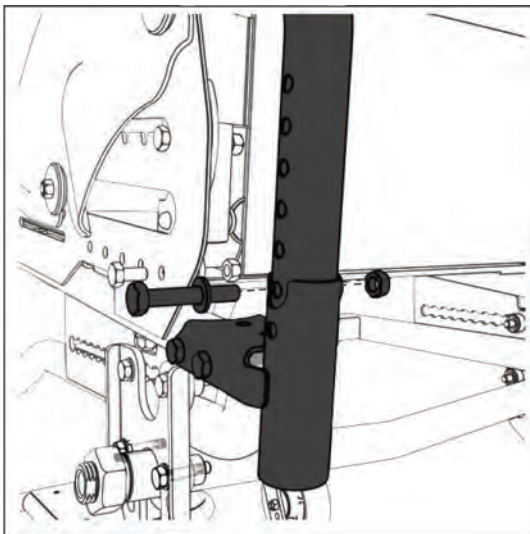
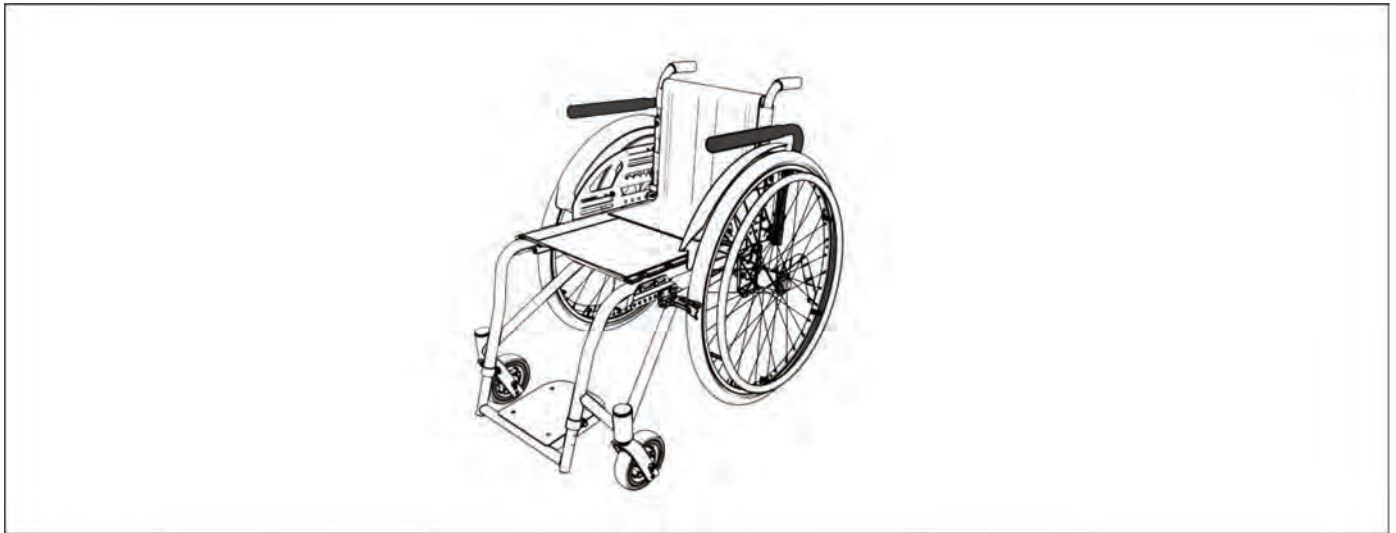

## STEP 1

Remove bolt and replace to fit the user's needs.



# Wheels for Humanity

a subsidiary of **UCP** United  
Cerebral  
Palsy™  
of Los Angeles

# Question ?

**Contact Us:**  
**[info@ucpwfh.org](mailto:info@ucpwfh.org)**

**or check:**  
**[info@ucpwheels.org/product](mailto:info@ucpwheels.org/product)**

# Wheels for Humanity

a subsidiary of **UCP** United  
Cerebral  
Palsy  
of Los Angeles